



Trellex Loading Station



Loading – a critical point in material handling

Loading is normally the critical point for the conveyor belt where many incidents of damage occur. The material drop height, lump size, speed and direction are all contributory factors to causing damage to belts, conveyors and conventional idler sets. Such problems are virtually eliminated using the Trellex Loading System. The system replaces conventional conveyor rollers and absorbs the impact energy from falling rocks while supporting the edge of the belt. The conveyor belt is protected from shearing and the risk for belt mistracking is reduced.

Trellex Impact Bars – a quick-return investment

Metso is constantly developing new advanced conveyor accessories that are tested in extremely tough environments, which accounts for the progress made in fields such as adhesion research, i.e. the potential for combining rubber with metals, plastics and other materials. Trellex Impact Bars consist of a top layer, an absorbing layer and a fastening profile. The top layer is of ultra-high molecular polyethylene providing low friction against the belt while the rubber absorbs the impact energy from falling material. In addition, the plastic is resistant to oil, grease and most industrial chemicals. The system provides effective protection against damage to conveyors and conveyor belts during loading. Trellex Impact Bars dramatically reduce maintenance costs, extend the working life of belts and conveyors and create a better work environment.



No moving parts – minimal maintenance

Using Trellex Impact Bars radically reduces maintenance costs. Conventional idler sets often breakdown resulting in damage to belts and long operational stoppages. The Trellex Loading System has no moving parts, which eliminate the problem of seized bearings and idle rollers. You avoid the time-consuming work involved in replacing defective rollers while raising operational reliability at the same time. The combination of energy absorbing stationary bars and effective sealing prevents material spillage and reduces cleaning costs, which is why the Trellex Loading Station is frequently used for belts transporting smaller material sizes.

Trellex Glide bars – a vital part of the sealing system

Trellex Glide bar has a yellow top layer of the same quality as the Trellex Impact Bars, and is used on the troughed sides when transporting light material. It supports the belt edge thereby preventing sag between the conveyor rollers, which provides an even surface for the sealing system to seal against. In combination with the Trellex Sealing System this effectively prevents dust and material spillage. The sealing system uses material with a slightly lower wear resistance than the belt. In this way you can confine wear to the sealing strip thus extending the working life of the significantly more expensive belts.

Trellex Wear Liner – a requirement for effective sealing.

If the loaded material is allowed to press against the sealing strip it will eventually work its way under it. By fitting a Trellex Wear Liner in the lower section of the loading zone, the material is kept away from the side seal. This substantially reduces the risk of spillage and wedging which would otherwise lead to increased wear or damage to the belt.

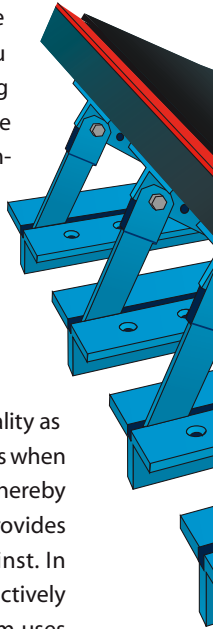

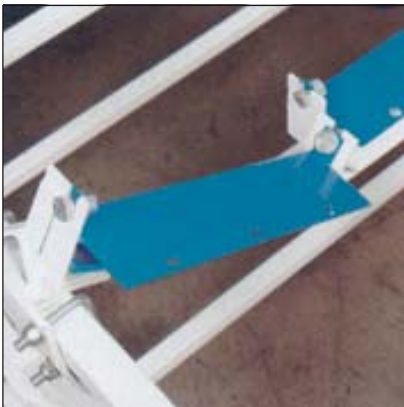
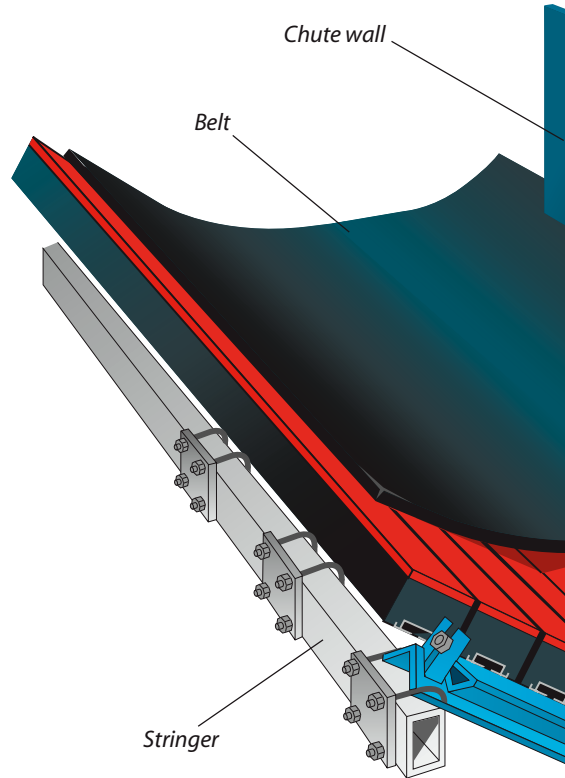
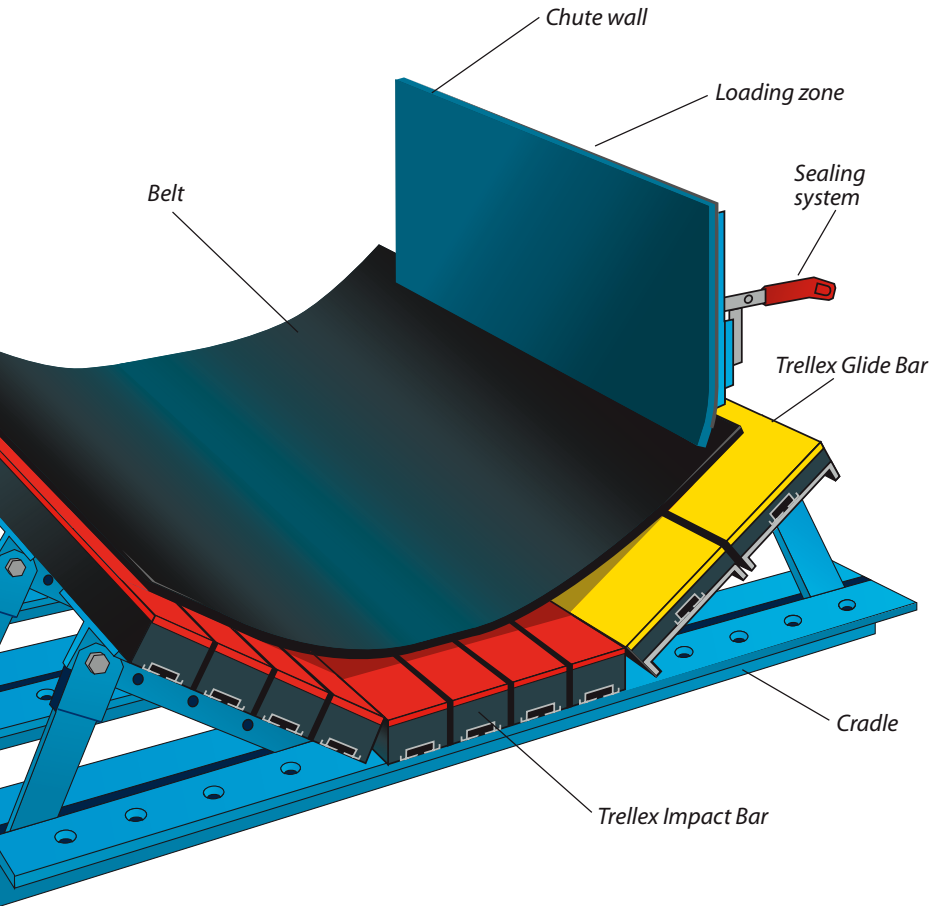

The adapter installed slightly below the belt, to absorb impact without constant wear.



An adapter allows existing idler support to be used.



The optimal construction for installation and servicing is achieved by using a cradle.

Conveyor components

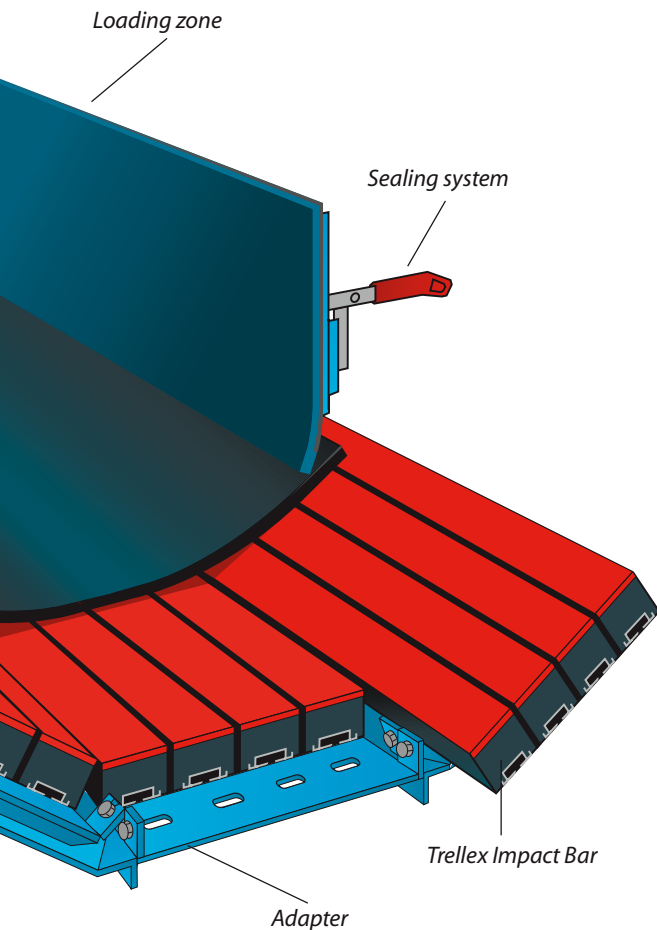

Quick and easy fitting reduces downtime

The fastening system with T-bolts means rapid and simple mounting. Selecting Trellex Adapter, which provides the option of using existing belt conveyor rollers, further helps installation. The most stable and complete construction for installation and control is achieved by using a complete cradle unit that replaces the existing conveyor rollers. By angling the wing sections a little more than the conveyor rollers, the belt edge gets excellent support and material spillage is avoided.

Correct installation gives extended working life

When using an impact bed, it is important that it is installed in the correct way. The top of the bar can withstand temperatures up to 85°C. The material will soften at higher temperatures. It is therefore important to leave a gap between the bars and the underside of the belt so that contact is only temporary. Sag between the carrying rollers corresponds to the tensile properties of the belt. Sag for conventional textile belts are about 1% of the gap between the supporting points. To prevent rapid wear, the distance between the belt and impact bar should be the sag distance plus 15mm.

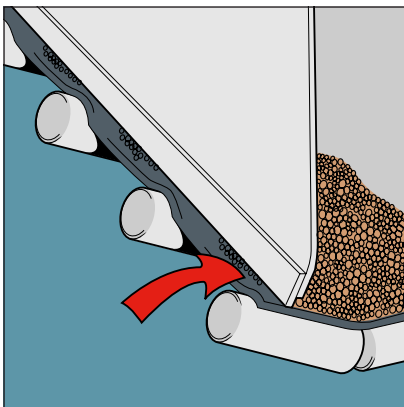

The conveyor belt sag between conveyor rollers causes material spillage

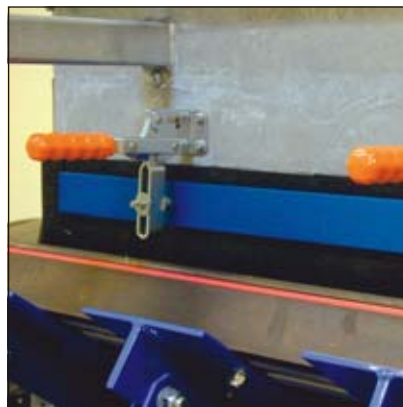

Trellex Clamp-On Sealing system provides effective sealing.



The longitudinal aluminium profile together with the T-bolt system provides simple and reliable fit.

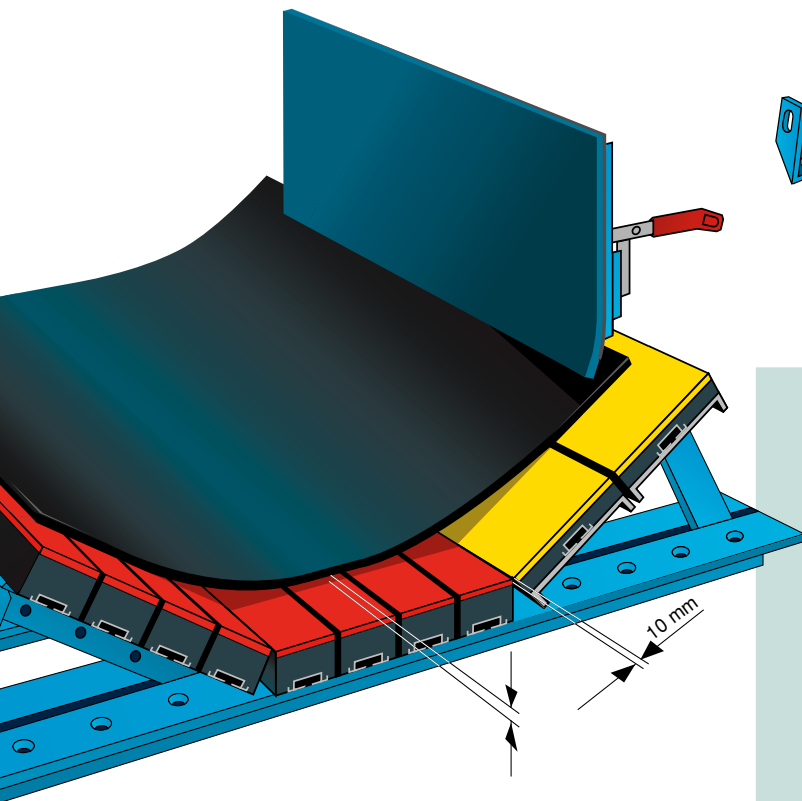

Impact cradle installed slightly below the belt, to absorb impact without constant wear.

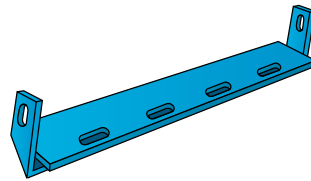

Adapter

To be used in existing idler support

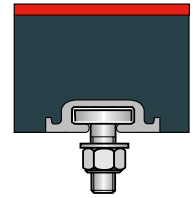

T-bolt system

TF 35/25 M12 x 40 x 35 or
TF 35/55 M16 x 70 x 50
4/bar 1220 length
5/bar 1520 length

Recommended number of impact bars

Belt width mm	Side/centre/side	Std.roll width mm
500	2+2+2	200
650	2+2+2	250
800	2+3+2	315
1000	3+3+3	380
1200	3+4+3	465
1400	4+5+4	530
1600	5+5+5	600
1800	5+6+5	670
2000	6+6+6	750

Distance between the trough sides and centre 10 mm maximum.



Trellex Impact bar

- Top layer: 8 mm thick Ultra high molecular polyethylene giving low friction between belt and Trellex Impact bar
- Intermediate layer: Special soft rubber for high energy absorption
- Fastening: Vulcanized-in, longitudinal aluminium profiles
- Dimensions (LxWxH): 1220 x 100 x 75, 1520 x 100 x 75 mm, 1220 x 100 x 50, 1520 x 100 x 50 mm

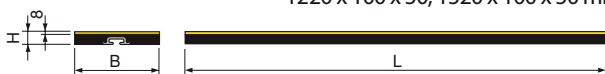

Trellex Glide bar

- Top layer: 8 mm thick. Ultra-high molecular weight polyethylene
- Intermediate layer: 22 mm dampening rubber grade
- Fastening: Vulcanized-in, longitudinal aluminium profiles
- Dimensions (LxWxH): 1120 x 200 x 30 and 1120 x 300 x 30 mm

Formula for calculating belt sag

The normal belt sag for EP-belts in approx. 1%, i.e. for Trellex Impact bar length 1220 mm will the sag be $1200 \cdot 0.01 = 12$ mm. However the normal belt sag for different types of conveyor belts can also be calculated, in order to get a more exact position when installing the impact bars. See example below.

$$t = \frac{a^2 \cdot g(qB + qG)}{8 \cdot T \cdot 1000}$$

- t = sag in mm
- a = length of Trellex Impact bar installation in mm
- T = belt tension in the relevant belt section in Newton (N)
- g = 9.81 m/s²
- qB = belt weight per meter (kg/m)
- qG = weight of transported material per meter (kg/m)

Example: $t = \frac{1220^2 \cdot 9.81(10 + 100)}{8 \cdot 20000 \cdot 1000} = 10$ mm

In this example the belt is sagging 10 mm per 1220 mm. To avoid continuous friction, 15 mm clearance needs to be added giving a total distance of 25 mm.

